

TIA-1200

Optical/Electrical Converter

Manual



TREND NETWORKS

Depend On Us

<u>Topic</u>	<u>Page</u>
GENERAL INFORMATION	
Introduction	3
Specifications	4
Unpacking and Inspection	5
Power Supply	5
Operational Considerations	6
Typical Frequency Response	6
Spectral Response	7
Warranty and Repair Information	8

INTRODUCTION

The TIA-1200 Optical to Electrical Converter is a wide-band detection system for fiber optic applications. With a typical bandwidth of DC to 12 GHz, it accurately provides an electrical replica of the optical signal presented to it. It is intended to drive a 50 Ohm cable terminated in its characteristic impedance. The unit is equipped with an InGaAs/InP detector that is responsive in the wavelength range of 900 - 1700 nm. The TIA-1200 is provided with an FC fiber optic receptacle. Other fiber optic connectors can be provided on request. The output signal is presented to a type K SMA female connector.

Calibration - This is a qualitative measurement device. No calibration is required or necessary.

FEATURES AND BENEFITS

- Large Area InGaAs detector
- DC to 12GHz Bandwidth
- 900-1700nm
- Universal Power Supply
- Capability to drive 50 Ohm output loads



MADE IN THE USA

Specifications	
Detector Type	InGaAs/InP (900-1700nm)
Current Responsivity	0.7 A/W @1300 nm, 0.8 A/W @ 1550nm Typical
Maximum Linear Input Power	3mw
Maximum Input Power without Damage	10mw
Bandwith-(3dB)	DC to 12GHz Typical, 10 GHz Minimum
Output Impedance	50 Ohms
Output Connector	Type K SMA Female
Fiber Optic Input Connector	FC or FC/APC
Input Numerical Aperture	0.11
Optical Return Loss	>35dB, >52dB with APC Connection
Power Requirments	120/240 VAC, 50-60Hz
Dimensions	1.2"W x 2.5"L x 1.3"H (30.5mm x 63mm x 33mm)
Weight	2.8 oz (0.08 Kg)
LED Annunciators Provided	Power On
Operating Temperature Range	0 - 40 C
Standard Warranty	Two Years, Component and Workmanship, 30 Day Satisfaction Guarantee
Accessories Supplied	Transit/Storage Case, Operating Manual, Universal Power Supply

UNPACKING AND INSPECTION

Prior to shipment this instrument was inspected and found to be free of mechanical and electrical defects. Upon acceptance by the carrier he assumes responsibility for its safe arrival. After unpacking, examine the unit for any evidence of shipping damage. Should you receive this instrument in a damaged condition, apparent or concealed, it must be noted on the freight bill or express receipt and signed by the carrier's agent. Failure to do so could result in the carrier refusing to honor the claim. Upon filing a claim TREND Networks should be notified.

POWER SUPPLY

Each unit comes equipped with a 9 V regulated power supply that provides power to the unit. Simply plug the power supply output cable into the receptacle located beneath the FC fiber optic connector. It is recommended that the user never attempt substitution of this unit with any other power supply. Reverse polarity or voltages other than 9 Volts may irreparably damage the unit. The power supply can be used with mains of either 120 or 240 VAC, 50-60 Hz. Several replaceable power plug adaptors are supplied for use in various countries.

TYPICAL SETUP

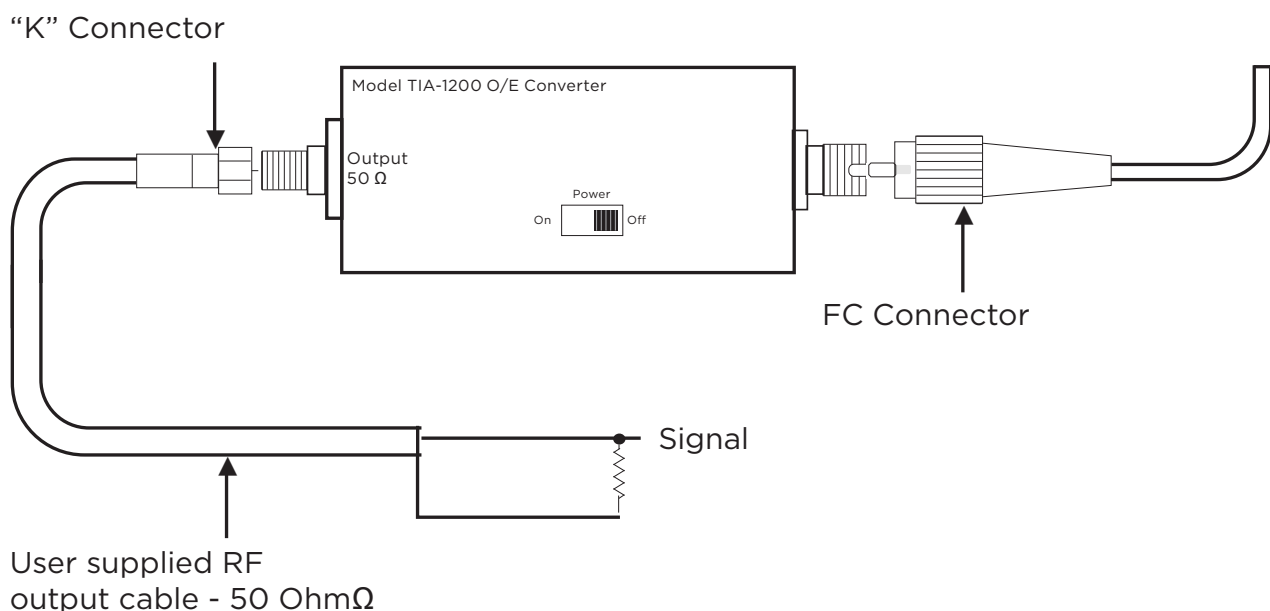

OPERATIONAL CONSIDERATIONS

The TIA-1200 is comprised of a fiber coupled InGaAs detector coupled with a reverse bias voltage network. The output of the diode is brought out to a type K female SMA connector. Light falling on the detector generates a positive-going proportional current. This current, multiplied by the load impedance produces a voltage that is proportional to the light incident on the detector surface.

Normally the unit is used to drive a coaxial cable, this cable should have a 50 ohm characteristic impedance and be terminated with a 50 ohm load at the oscilloscope or other measuring device to be used.

The active area of the TIA-1200 is 50 microns in diameter. With the optional 50 micron fiber both singlemode and multimode sources may be tested without incurring excessive coupling losses.

Typical optical return loss is 35 dB and is caused primarily by the FC/PC connector employed. If higher return loss is needed, The unit may be optionally equipped with singlemode angled PC connectors for ORLs of around 52 dB.

TYPICAL FREQUENCY RESPONSE

The bandwidth of the TIA-1200 is from DC to typically 12 GHz (-3 dB). Refer to the following Bode plot

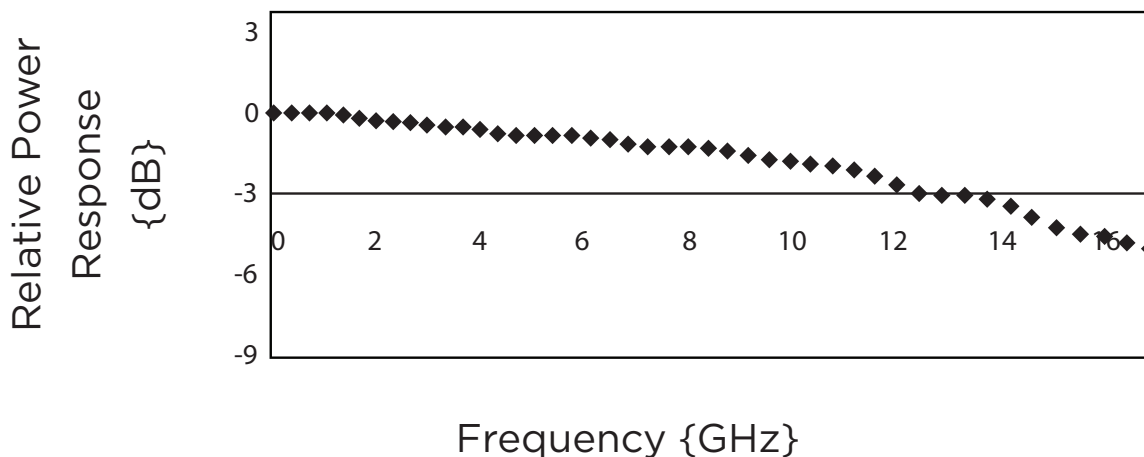

SPECTRAL RESPONSE

The approximate relative response curves of the detectors employed is as shown below. Note that these are representative curves and do not necessarily correspond to the exact response of the particular detector in use.

The approximate power at the detector surface is given by:

InGaAs Detector Spectral Response

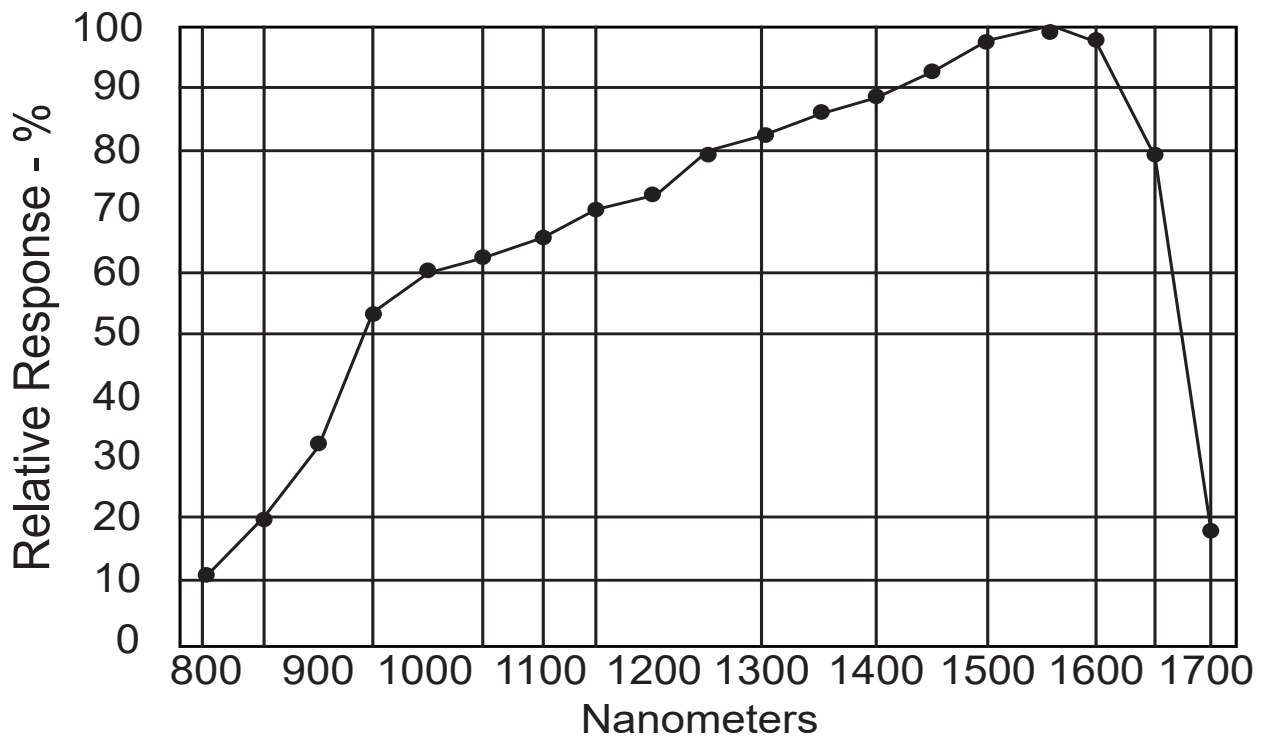

WARRANTY AND REPAIR INFORMATION

REPAIR INFORMATION

Products manufactured by TREND Networks are designed and manufactured to provide reliable performance. However, in the event that service is required, both telephone technical assistance and factory repair services are available. Call (973) 957-7700, e-mail contactus@trend-networks.com or visit our web site at <https://www.trend-networks.com/us/> for more information or to request an RMA number.

For IN-WARRANTY REPAIRS, call us to obtain a Returned Material Authorization number, (RMA Number). All products are to be returned to TREND Networks with freight charges pre-paid. Those products sent under warranty will be returned to our customers pre-paid. We cannot be responsible for returned products that do not reference the TREND Networks RMA number.

For OUT-OF-WARRANTY repairs, services are billable for both time and materials.

LIMITED WARRANTY

TREND NETWORKS WARRANTS THAT TO THE FIRST PURCHASER, FOR A PERIOD OF TWO YEARS FROM THE DATE OF RECEIPT, THAT THIS PRODUCT (THE PRODUCT) WILL BE FREE FROM DEFECTS IN MATERIALS AND MANUFACTURING. THE FOREGOING WARRANTY IS THE ONLY WARRANTY, EXPRESS OR IMPLIED, GIVEN BY TREND NETWORKS, I.E., THERE IS NO WARRANTY OF FITNESS FOR A PARTICULAR PURPOSE. TREND NETWORKS HEREBY DISCLAIMS ANY EXPRESS OR IMPLIED WARRANTY OTHER THAN THE WARRANTY IN THE FIRST SENTENCE TO THE FULLEST EXTENT PERMITTED BY LAW.

THE SOLE AND EXCLUSIVE REMEDY UNDER THIS WARRANTY IS REPAIR OR REPLACEMENT AT TREND NETWORKS' OPTION OF ANY PRODUCT THAT PROVES TO BE DEFECTIVE IN MATERIALS OR MANUFACTURING WITHIN TWO YEARS OF RECEIPT OF THE PRODUCT. NOTE: THIS WARRANTY DOES NOT APPLY TO ANY PRODUCT WHICH HAS BEEN SUBJECT TO MISHANDLING, MISUSE, OR SERVICE BY UNAUTHORIZED PERSONNEL OR TO ANY PRODUCT WHICH HAS BEEN DAMAGED, MODIFIED, ALTERED OR TAMPERED WITH.

TO THE FULLEST EXTENT OF THE LAW, TREND NETWORKS DISCLAIMS ALL LIABILITY FOR ANY OTHER DIRECT, INCIDENTAL OR CONSEQUENTIAL DAMAGES ALLEGED TO BE CAUSED BY A DEFECTIVE PRODUCT, I.E., TREND NETWORKS WILL NOT BE RESPONSIBLE FOR ANY PERSONAL INJURY, PROPERTY DAMAGE OTHER THAN THE COST OF REPLACING THE PRODUCT OR ANY OTHER MONETARY DAMAGE SUCH AS LOST WAGES OR PROFITS CAUSED BY ANY USE, ATTEMPTED USE OR INABILITY TO USE THE PRODUCT. NOTE: BY USING THE PRODUCT, YOU AGREE THAT REPAIR OR REPLACEMENT AT TREND NETWORKS' OPTION WILL FULLY SATISFY TREND NETWORKS WARRANTY OBLIGATION TO YOU, WHETHER IN CONTRACT, TORT, NEGLIGENCE, STRICT LIABILITY OR OTHER APPLICABLE LAW.



TREND NETWORKS North America
300 Roundhill Drive, Suite 1,
Rockaway, NJ 07866, USA
Tel. 973-957-7700
contactus@trend-networks.com

www.trend-networks.com

TREND Networks logos are trademarks or registered trademarks of TREND NETWORKS.



Specification subject to change without notice. E&OE
© TREND NETWORKS 2022